

The Almuñécar Aquarium Textile Roof

Josep Ignasi de LLORENS DURAN

School of Architecture, Technical University of Catalunya
Diagonal, 649 – 08028 Barcelona, Spain

ignasi.llorens@upc.edu



Abstract

The Almuñécar Aquarium is a 3000 m² underground installation that shows Mediterranean fauna on two levels below the Kuwait Square next to the market and near the City Hall of the andalusian town of Almuñécar (Spain). The Aquarium emerges to the surface by means of its control building, staircase and lift, all arranged around an open courtyard. We designed a textile roof in order to protect this courtyard from direct sunshine and rain. As the only part of the building that shows above is the membrane, it has also been envisaged as an eye catcher in order to attract visitor's attention. Two water ponds reflect the white and lofty membrane set in front of the backdrop of white apartment buildings.

Keywords: textile roof, structural membrane

SECCIÓN TRANSVERSAL
 e: 1/100

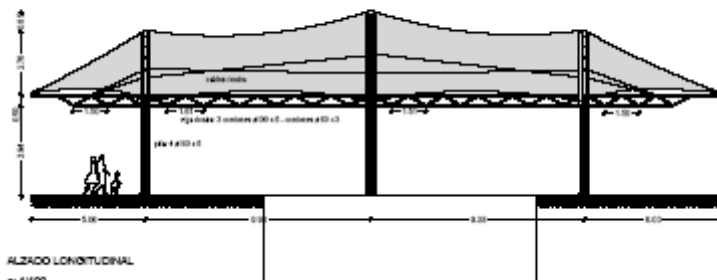
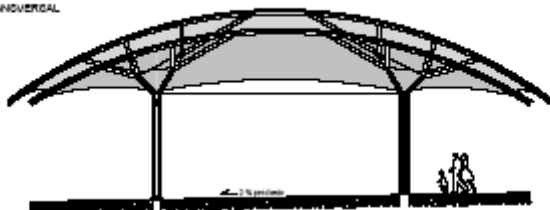

ALZADO LONGITUDINAL
 e: 1/100

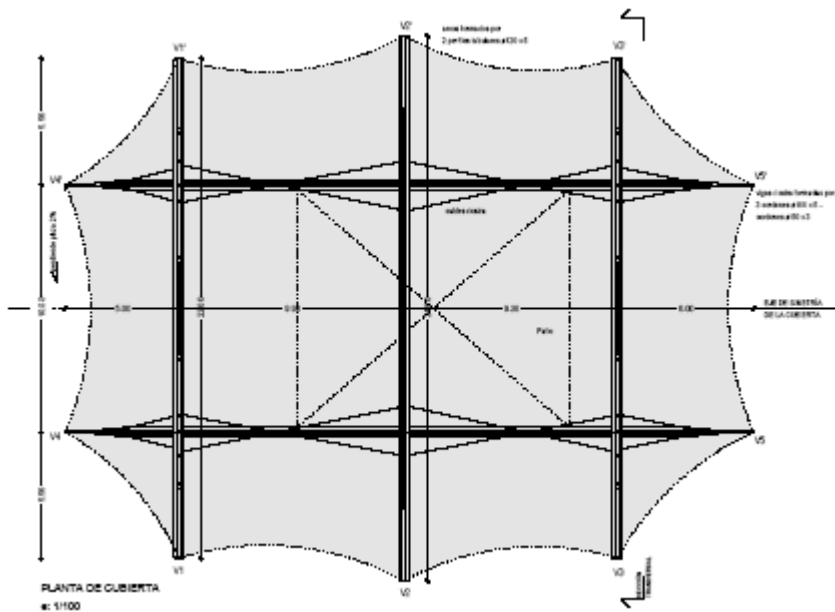

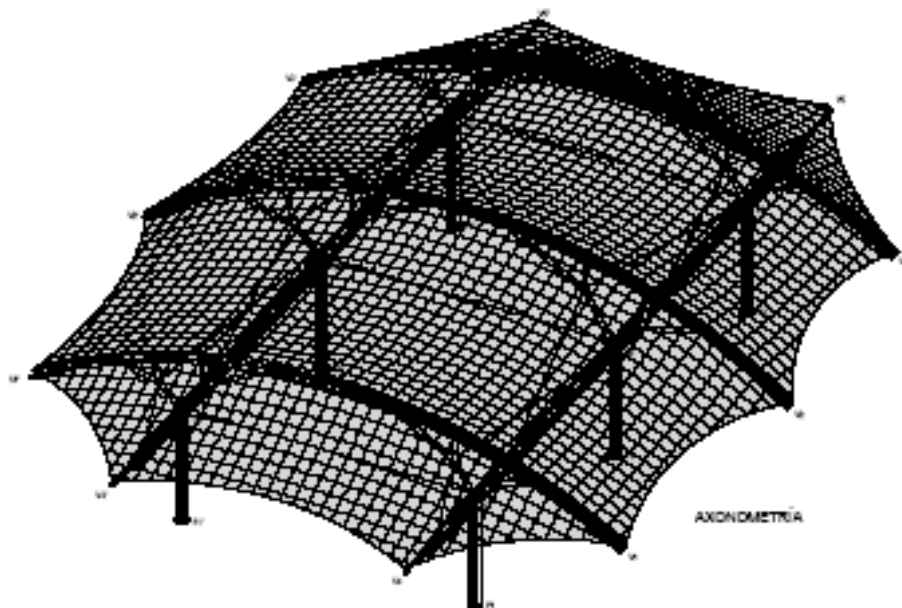

1. Introduction

The Almuñécar Aquarium is a 3000 m² underground installation that shows 3500 specimen belonging to 200 species swimming into 2 million litres of water. It is located under a 2566 m² spot in the Kuwait Square, situated beside the market, near the City Hall of Almuñécar (Spain). The Aquarium emerges to the surface by means of its control building, staircase and lift, arranged around a courtyard. To protect them and finish the ensemble, a textile roof has been envisaged as an eye catching advertisement to attract visitors attention.

2. Structure

The textile roof is supported by three porticos set 9 and 10 m apart. The porticos are arches 22, 24 and 22 m in length, held on 6 masts set 11 m apart. The masts are anchored to the top slab of the aquarium and correspond in position to the reinforced concrete columns underneath. The arches are only pairs of CHS because the spans are reduced drastically by means of branching the masts as trees. Trussed beams between porticos provide stability and take the prestress of the fabric in the longitudinal direction.



Mast, branches and beams. The cables slacken after pretensioning. Trussed beams provide stability and take the prestress of the fabric.

3. Membrane

The membrane was manufactured in only one piece to avoid joining on site. It is fixed to 10 peripheral points and simply leans on the arches without any device to fix it on them. There are two different corners according to whether they are subjected to the arches or to the beams. At the end of the arches, a circular bended plate allows for different directions of edge cables and corner plates. At the end of the beams, a plate is welded perpendicularly to the direction of the corner plate and extra holes are provided for ease of installation and prestress.

4. Redundancy

Ties of the arches and cables bracing the whole structure were relaxed after pretension of the membrane. It means that they were replaced functionally. Nevertheless, it is advisable to maintain them in place preventing a general distortion or collapse from local failures.

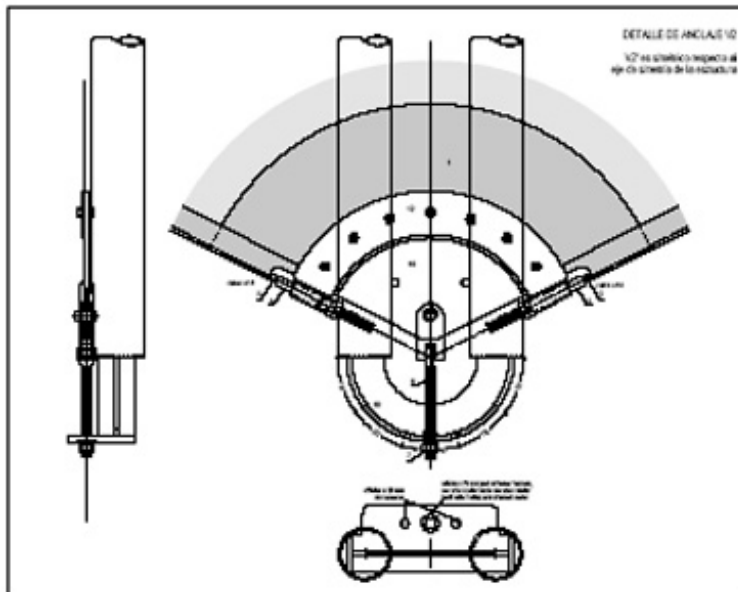

At the end of the arches, a circular bended plates allows for different directions of edge cables and corner plates.



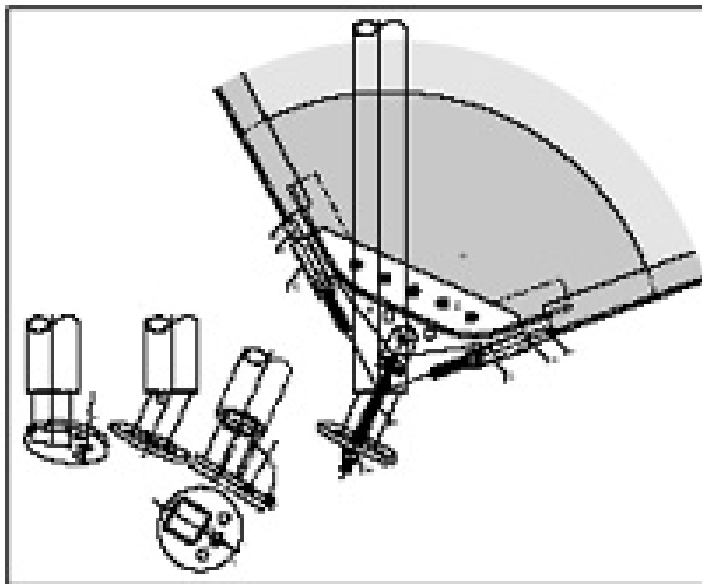

At the end of the beams a plate is welded perpendicular to the direction of the corner plate. Extra holes are provided for ease of installation and prestress





The branches reduce drastically the span of the arches



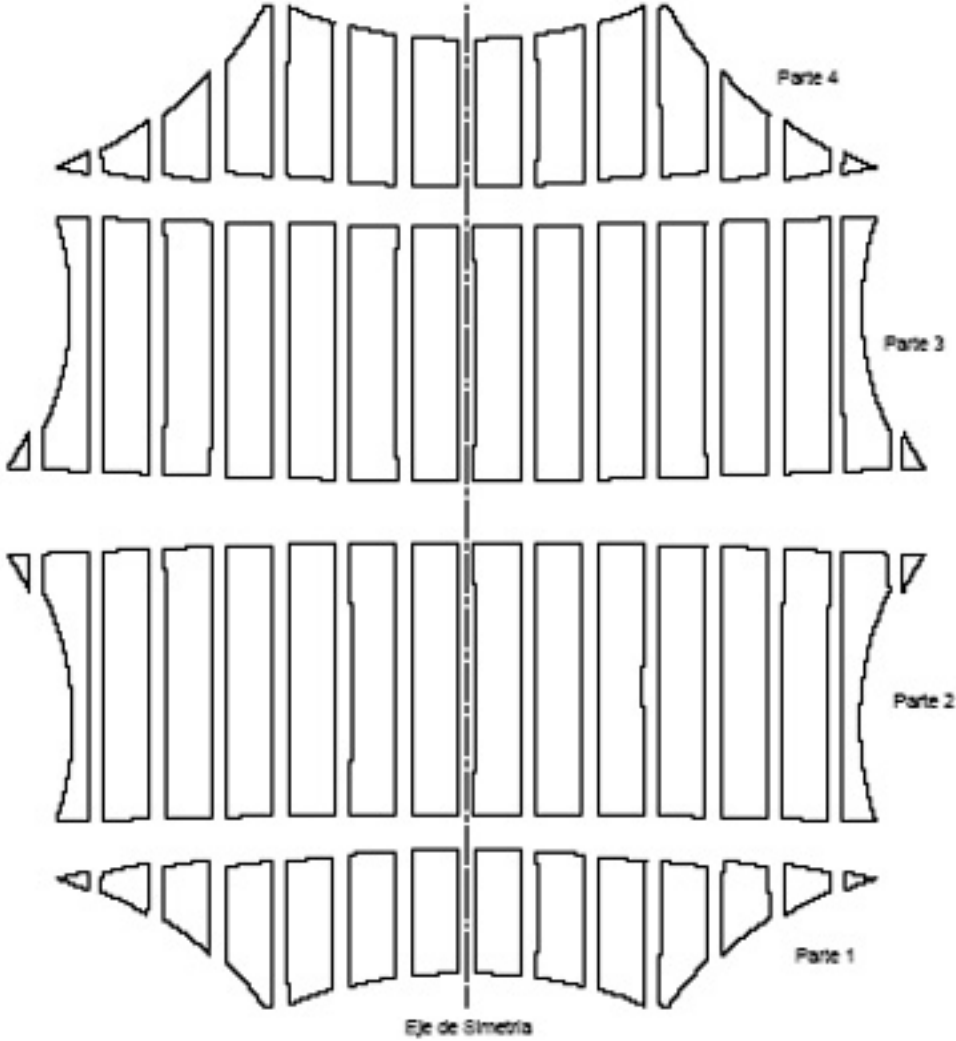

Cutting pattern

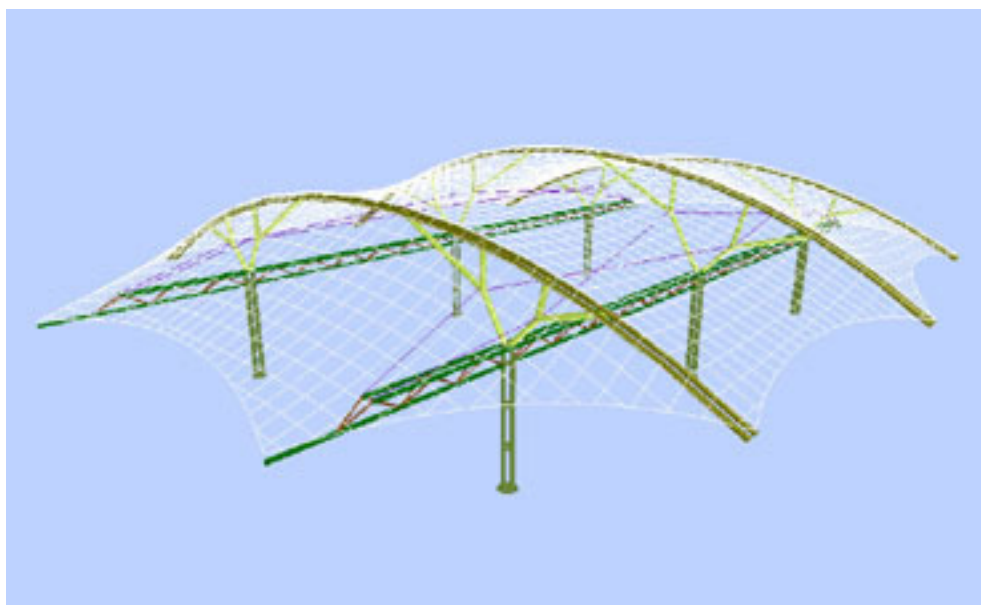
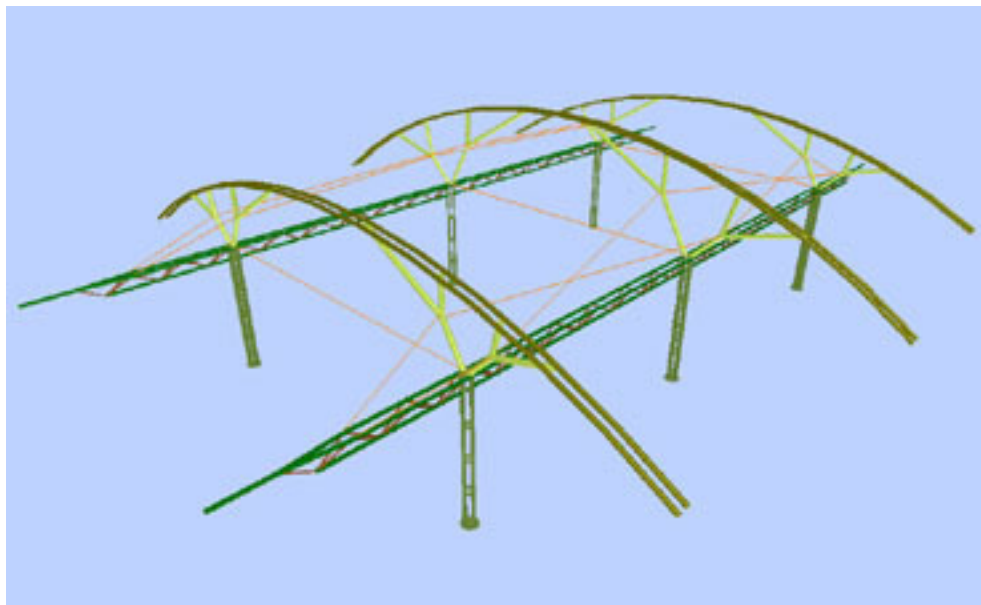

Design perspective views. Top: steel structure. Bottom: with the membrane

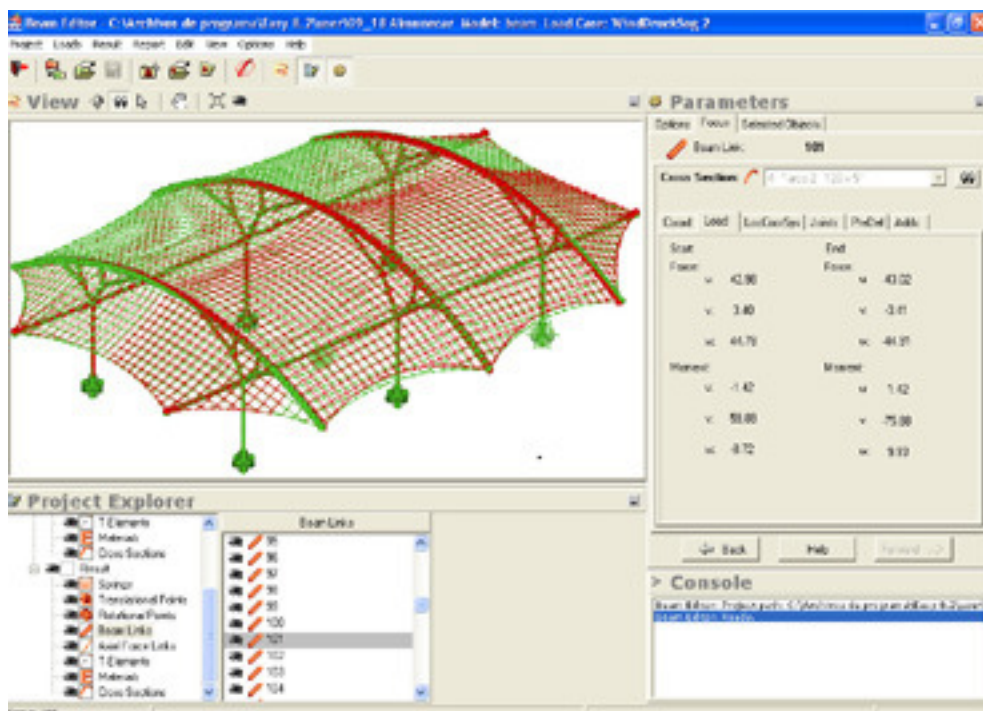

5. Conclusions

Main features of the design are:

- The membrane was manufactured in only one piece to avoid joining on site. It is fixed to 10 peripheral points and simply leans on the arches without any device to fix it on them.
- The singularity of the design that has been built recently, consists on the aforementioned features and also on the structural analysis of the membrane that was carried out including the steel branched supports, beams and arches. The results were amazing compared with the independent computations of each part.

6. Credits

Client: AQUASCENIC,S.L.

Location: Kuwait Square, Almuñécar, Spain

General Architect for the Aquarium: Carlos Javier Jiménez González

Architects and Structural Engineers for the steel structure and textile roof: Arqintegral: Ch.Garcia-Diego, J.Llorens & H.Pöppinghaus

Membrane: PVC coated polyester FERRARI Précontraint 1202 with FLUOTOP surface treatment

Roofed area: 700 m²

Manufacturing and installation: T&P Construcció Tèxtil s.c.p. Cornellà de Terri, Spain

Year of construction: 2007